



DUNIFORM®

| Film & Machine Guide 2025

DF22/DF22F



DF25



DF20



DF15



DF10



DF5



A MACHINE FOR EVERY NEED

Our in-house team can help you choose the optimal Duniform® machine for your company. While each machine suits different businesses – from small delis to industrial-scale HMR firms – they are all designed with simplicity in mind. Whatever model you choose, the cassettes can be changed in moments.



FOR GLASSES

Serve sealed BioPak RPET glasses with speed and style.

DF32/DF32F



DF36



DF44



DF46



MANUAL

Simply lift and close the lid to seal your filled tray.



SEMI-AUTOMATIC

Simply push in the cassette to seal your filled tray.



FULLY-AUTOMATIC

The machine winds the trays, and is capable of large volumes.

OVERVIEW OF ALL OUR MACHINES



General Information	DF5	DF10	DF15	DF20	DF25	DF22	DF22F
Article number	700076	700080	163140	700095	700090	163141	164795
Machine weight	22 kg	13 kg	25 kg	20 kg	43 kg	30 kg	30 kg
Cassette weight	0,5 kg	0,5 kg	2,5 kg	0,5 kg	2,5 kg	1,0 kg	1,0 kg
Electrical data	220 V~, AC 50/60 Hz	230 V~, AC 50 Hz 10 A	230 V~, AC 50 Hz 10 A	230 V~, AC 50 Hz 10 A	230 V~, AC 50 Hz 10 A	230 V~, AC 50 Hz 10 A	230 V~, AC 50 Hz 10 A
Maximum power consumption	0,4 kW	0,7 kW	1,0 kW	0,75 kW	1 kW	0,8 kW	1,0 kW
Lengths of cable/ connection plug	2m/1-phase grounded	2,5 m / 1-phase grounded	2,5 m / 1-phase grounded	2,5 m / 1-phase grounded	2 - 3 m/1-phase grounded	2,0 m / 1-phase grounded	2,0 m /1-phase grounded
Pressing force		930 N	930 N	1003 N	1003 N	1400 N	1400 N
Capacity	6-10 cycles/min	8 cycles/min	8 cycles/min	10 cycles/min	10 cycles/min	2 - 4 cycles/min	2 - 4 cycles/min
Start-up heating time	5-10 min	15 min	20 min	15 min	20 min	10 min	10 min
Dimensions	DF5	DF10	DF15	DF20	DF25	DF22	DF22F
Length	350 mm base	640 mm (with handle) 540 mm (base)	830 mm (with handle) 740 mm (base)	615 mm	760 mm	550 mm	550 mm
Width	360 mm	240 mm	355 mm	220 mm	355 mm	325 mm	325 mm
Height	610 mm	260 mm (closed) 500 mm (open)	270 mm (closed) 660 mm (open)	220 mm (closed) 520 mm (open)	350 mm (closed) 650 mm (open)	450 mm	450 mm
Trays/Film/Sealing	DF5	DF10	DF15	DF20	DF25	DF22	DF22F
Maximum sealable dimension (length x width x depth)	Ø 98 mm	265x175x100 mm (>¼ GN)	325x265x100 mm (½ GN)	265x175x70 mm (>¼ GN)	325x265x100 mm (½ GN)	230x280x100 mm (>¼ GN)	230x280x100 mm (>¼ GN)
Maximum film width	130 mm	185 mm	272 mm	185 mm	272 mm	240 mm	240 mm
Sealing temperature	max 200°C	max 210°C	max 210°C	max 190°C	max 180°C	max 210°C	max 210°C
Sealing technique	Semi-automatic	Manual	Manual	Semi-automatic	Semi-automatic	Semi-automatic	Semi-automatic
MAP - Modified Atmosphere Packaging	-	-	-	-	-	-	-
Vacuum chambers	-	-	-	-	-	-	-
Figure cutting	Yes	-	-	-	-	-	Yes



DF32	DF32F	DF36	DF44	DF46
160900	159788	191000	160901	163142
approx. 40 kg	approx. 40 kg	approx. 100 kg	approx. 190 kg	approx. 550 kg
approx. 1,5 – 2,5 kg	approx. 3 – 4 kg	approx. 3 – 4 kg	approx. 4 – 6 kg	approx. 3 – 5 kg
230 V~, AC 50/60 Hz	230 V~, AC 50/60 Hz	230 V~, AC 50/60 Hz	400 V~, AC 50/60 Hz	400 V~, AC 50/60 Hz
1,8 kW	1,8 kW	2,5 kW	4,3 kW	6,3 kW
2 m / 1-phase grounded	2 m / 1-phase grounded	1,5 m / 1-phase grounded	- / 3-phase grounded	- / 3-phase grounded
2000 N	2000 N	2000 N	7000 N	-
2 – 4 cycles/min	2 – 4 cycles/min	2 with MAP, 2 – 6 without MAP	3 with MAP, 2 – 6 without MAP	2-6 with MAP, 5-9 without MAP
10 min	10 min	10 min	20 min	10 min
DF32	DF32F	DF36	DF44	DF46
550 mm	550 mm	650 mm	970 mm	3050 mm
475 mm	475 mm	530 mm	675 mm	905 mm
450 mm	450 mm	625 mm	1570 mm	1640 mm
DF32	DF32F	DF36	DF44	DF46
380x280x100 mm (>½ GN)	370x275x100 mm (>½ GN)	360x270x100 mm (>½ GN)	430x315x95 mm (>½ GN)	360x270x100 mm (>½ GN)
390 mm	390 mm	390 mm	470 mm	446 mm
max 200°C	max 200°C	max 200°C	max 200°C	max 200°C
Semi-automatic	Semi-automatic	Semi-automatic	Semi-automatic	Automatic
-	-	Yes	Yes	Yes
-	-	1	1	1
-	Yes	Yes	Yes	Yes

DUNIFORM® DF5 SEALING MACHINE CONCEPT

Health is wealth. No wonder that today's consumers are opting for nutritious, hygienically-served food and drinks: smoothies, freshly squeezed juices, protein shakes and healthy snacks are extremely popular. At the same time, customers everywhere are actively seeking solutions that are healthy for the future of the planet. The new Duniform® DF5 concept lets you deliver the best of both worlds - while optimising hygiene, minimising waste and working with effortless efficiency.



"Hygienically sealing in freshness and avoiding spills is good for customers and business."



compostable



SWEET CUP

Material: BAGASSE/PLA: up to +100°C
PLA max +40°C

No.	Article	Description	Colour	Material	Volume (ml)	Qty./Cart.	DF5 Cassette
1	208851	Sweet Cup	Printed	Bagasse	360	18x50	191377
2	208852	Sweet Cup	Printed	Bagasse	480	25x36	191377
3	192157	Breeze Cup	Printed	Bagasse	350	18x50	191377
4	192158	Breeze Cup	Printed	Bagasse	470	25x36	191377
5	192159	Breeze Cup	Printed	Bagasse	590	25x36	191377



RPET CRYSTAL GLASSES

Material: RPET 70°C



No	Article	Description	Material	Colour	Volume (ml)	Size	Pcs/SKU	DF5 Cassette
1	188001	Crystal Glass	RPET	Transparent	270	-	16x60	191380
2	188002	Crystal Glass	RPET	Transparent	360	-	16x60	191380
3	188004	RPET Crystal Glass	RPET	Transparent	410 (0,3l)	-	16x50	191378
4	188005	RPET Crystal Glass	RPET	Transparent	470 (0,4l)	-	16x50	191378
5	188006	RPET Crystal Glass	RPET	Transparent	590 (0,5l)	-	16x50	191378
6	188003	Crystal Glass Insert to be sealed with 188004 - 188006	RPET	Transparent	120	-	16x30	191377
7	177998	RPET Flat Lid (w/o hole)	RPET	Transparent	-	-	20x50	-
8	188012	RPET Dome Lid (w hole)	RPET	Transparent	-	-	20x50	-



DELIPACK

Material: PP max +100°C (microwarmable)



No.	Article	Description	Size (mm) LxWxH	Vol (ml)	Qty/ Cart.	DF5 Cassette
1	156421*	Delipack Round	101x101x30	125	20x50	191382
2	156422*	Delipack Round	101x101x37	200	20x50	191382
3	156423*	Delipack Round	101x101x48	250	20x50	191382
4	156424*	Delipack Round	101x101x61	300	20x50	191382



*Remove film before reheating in microwave

DUNIFORM® DF5 - DF46 SEALING MACHINES

Duni offers a variety of machines in its Duniform® Sealing Concept. Whatever your requirements or budget, we are certain you will find the right sealing solution for your operation.





DF5

- Small & compact
- Easy and fast

General Information	
Article number	700076
Machine weight	22 kg
Cassette weight	0,5 kg
Electrical data	220 V~, AC 50/60 Hz
Maximum power consumption	0,4 kW
Lengths of cable / connection plug	2m/1-phase grounded
Pressing force	
Capacity	6-10 cycles/min
Start-up heating time	5-10 min
Trays/Film/Sealing	
Maximum sealable glass dimension	Ø 98 mm
Maximum film width	130 mm
Sealing temperature	max 200°C
Sealing technique	Semi-automatic
Sealing film	188059

DF5 CASSETTES & FILM

No	Article	Description	Colour	Size (mm)	Qty./Cart.
1	191378	Cassette DF5 1-Cav	Black	Ø 92	1x1
2	191377	Cassette DF5 1-Cav	Red	Ø 85	1x1
3	191380	Cassette DF5 1-Cav	Blue	Ø 88	1x1
4	191381	Cassette DF5 1-Cav	Silver	Ø 90	1x1
5	191382	Cassette DF5 1-Cav	Green	Ø 96	1x1
6	188059	Sealing Film, 42 µ, 130 mm x 400 m	Transparent		1x1



1

2

3

4

5

6

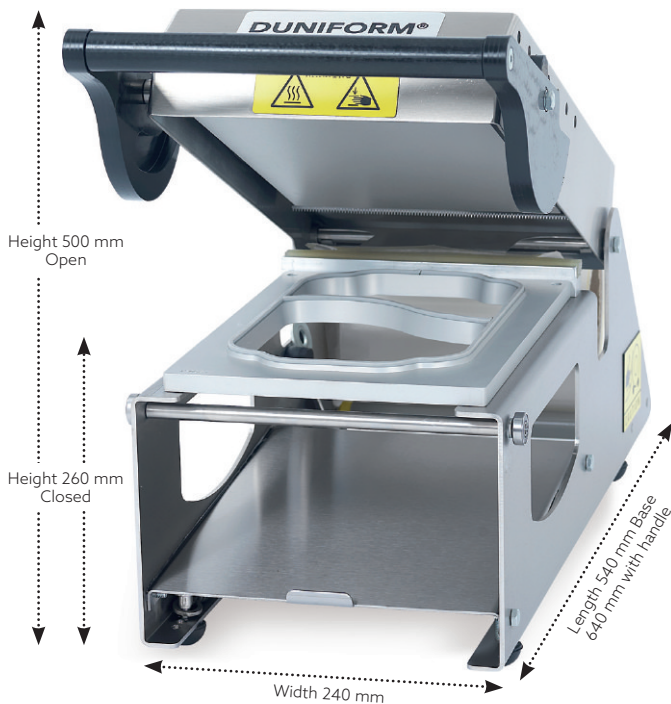

DF10

- Small & compact
- Easy and fast

General Information	
Article number	700080
Machine weight	13 kg
Cassette weight	0,5 kg
Electrical data	230 V~, AC 50 Hz 10 A
Maximum power consumption	0,7 kW
Lengths of cable / connection plug	2,5 m / 1-phase grounded
Pressing force	930 N
Capacity	8 cycles/min
Start-up heating time	15 min
Trays/Film/Sealing	
Maximum sealable tray dimension	265 x 175 x 100 mm (>¼ GN)
Maximum film width	185 mm
Sealing temperature	max 210°C
Sealing technique	Manual
Accessories	
Spike Roll DF10	155198

DF15

- Seals sizes up to 1/2 GN
- Easy & fast

General Information	
Article number	163140
Machine weight	25 kg
Cassette weight	2,5 kg
Electrical data	230 V~, AC 50 Hz 10 A
Maximum power consumption	1,0 kW
Lengths of cable / connection plug	2,5 m / 1-phase grounded
Pressing force	930 N
Capacity	8 cycles/min
Start-up heating time	20 min
Trays/Film/Sealing	
Maximum sealable tray dimension	325 x 265 x 100 mm (½ GN)
Maximum film width	272 mm
Sealing temperature	max 210°C
Sealing technique	Manual
Accessories	
Adapter for DF20/10 Cassettes	141549
Spike Roll DF15	166799





DUNIFORM®





DF20

- Semi-automatic
- Light and robust
- Digital display

General Information

Article number	700095
Machine weight	20 kg
Cassette weight	0,5 kg
Electrical data	230 V~, AC 50 Hz 10 A
Maximum power consumption	0,75 kW
Lengths of cable / connection plug	2,5 m / 1-phase grounded
Pressing force	1003 N
Capacity	10 cycles/min
Start-up heating time	15 min

Trays/Film/Sealing

Maximum sealable tray dimension	265 x 175 x 70 mm (>¼ GN)
Maximum film width	185 mm
Sealing temperature	max 190°C
Sealing technique	Semi-automatic

Accessories

Cassette Rack DF20	102014
Spike Roll DF20	102903

DF25

- Seals sizes up to 1/2 GN
- Robust
- Semi-automatic

General Information

Article number	700090
Machine weight	43 kg
Cassette weight	2,5 kg
Electrical data	230 V~, AC 50 Hz 10 A
Maximum power consumption	1,0 kW
Lengths of cable / connection plug	2-3 m / 1-phase grounded
Pressing force	1003 N
Capacity	10 cycles/min
Start-up heating time	20 min

Trays/Film/Sealing

Maximum sealable tray dimension	325 x 265 x 100 mm (½ GN)
Maximum film width	272 mm
Sealing temperature	max 190°C
Sealing technique	Semi-automatic

Accessories

Adapter for DF20/10 Cassettes	141549
Spike Roll DF25	108824
Trolley	887100



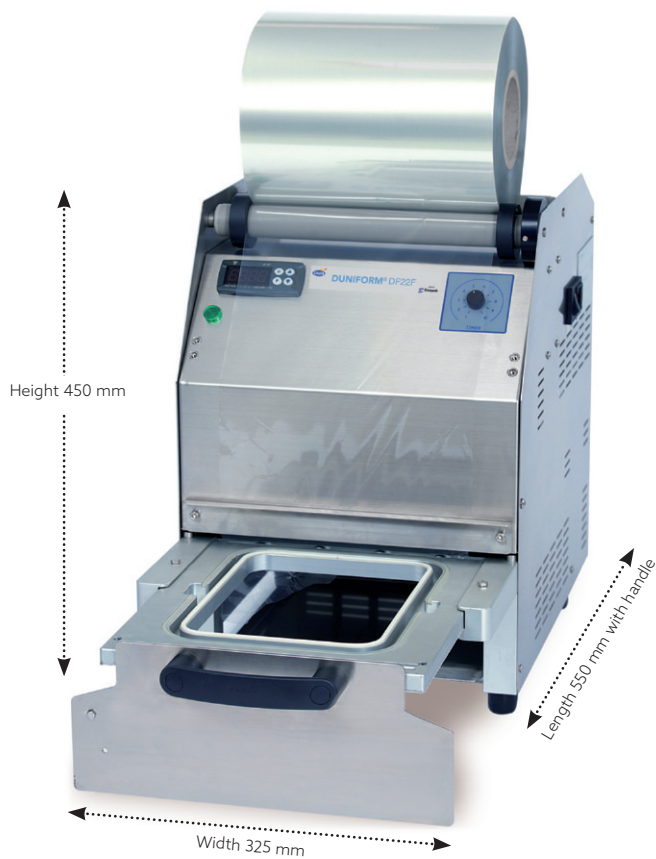

DF22/22F

- Small & compact
- Semi-automatic
- Figure cutting available

General Information	
Article number	163141/164795
Machine weight	30 kg
Cassette weight	1,0 kg
Electrical data	230 V~, AC 50 Hz 10 A
Maximum power consumption	0,8 kW
Lengths of cable / connection plug	2,0 m / 1-phase grounded
Pressing force	1400 N
Capacity	2-4 cycles/min
Start-up heating time	10 min
Trays/Film/Sealing	
Maximum sealable tray dimension	230 x 280 x 100 mm (>¼ GN)
Maximum film width	240 mm
Sealing temperature	max 210°C
Sealing technique	Semi-automatic
Figure cutting	Yes (164795)
Accessories	
Spike Roll DF22/22F	168744
Trolley	887100
Trolley	161965

DF32/32F

- Seals sizes larger than 1/2 GN
- Small & compact
- Figure cutting available

General Information	
Article number	160900/159788
Machine weight	approx. 40 kg
Cassette weight	2-3 kg
Electrical data	1/N/PE 230 V~, AC 50/60 Hz
Maximum power consumption	1,8 kW
Lengths of cable / connection plug	2 m / 1-phase grounded
Pressing force	2000 N
Capacity	2-3 cycles/min
Start-up heating time	10 min
Trays/Film/Sealing	
Maximum sealable tray dimension	380 x 280 x 100 mm (>½ GN)
Maximum film width	390 mm
Sealing temperature	max 200°C
Sealing technique	Semi-automatic
Figure cutting	Yes (159788)
Accessories	
Spike Roll DF32/32F	164020
Trolley	887120
Trolley	161965





DF36

- Compact & robust
- Figure cutting
- Programmable cycles
- MAP

General Information	
Article number	191000
Machine weight	approx. 100 kg
Cassette weight	3- 4 kg
Electrical data	1/N/PE 230 V~, AC - 50/60 Hz
Maximum power consumption	2,5 kW
Lengths of cable / connection plug	1,5 m / 1-phased grounded
Pressing force	2000 N
Capacity	2 with MAP, 2 - 6 without MAP
Start-up heating time	10 min
Trays/Film/Sealing	
Maximum sealable tray dimension	360 x 270 x 100 mm (>½ GN)
Maximum film width	390 mm
Sealing temperature	max 200°C
Sealing technique	Semi-automatic
Vacuum chambers	1
Figure cutting	Yes
Accessories	
Spike Roll DF36	168744
Vacuum Pump 20m³/h	166472
Trolley	887100
Trolley	161965



DF44

- MAP
- Robust
- Automatic film winding
- Figure cutting

General Information	
Article number	160901
Machine weight	approx. 190 kg
Cassette weight	4-6 kg
Electrical data	3/N/PE 400 V~, AC - 50/60 Hz
Maximum power consumption	4,3 kW
Lengths of cable / connection plug	- / 3-phase
Pressing force	7000 N
Capacity	3 with MAP, 2 - 6 without MAP
Start-up heating time	20 min
Trays/Film/Sealing	
Maximum sealable tray dimension	430 x 315 x 95 mm (>½ GN)
Maximum film width	470 mm
Sealing temperature	max 200°C
Sealing technique	Semi-automatic
MAP - Modified Atmosphere Packaging	Yes
Vacuum chambers	1
Figure cutting	Yes
Accessories	
Spike Roll DF44	164020
Compressor	152556
High Oxygene Vacuum Pump 40 m³/h	166473
High Oxygene Vacuum Pump 60 m³/h	166474
Food Filter DF44	168631

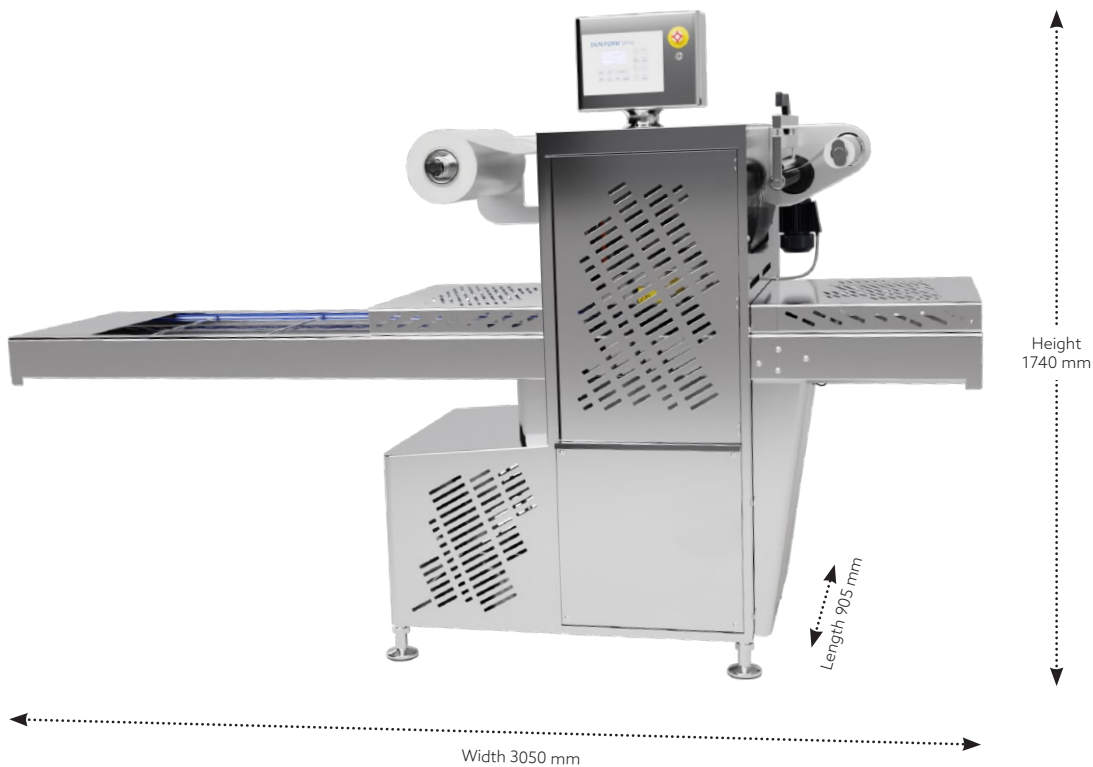

DF46

- Fully automatic
- MAP
- Film winding
- Figure cutting

General Information	
Article number	163142
Machine weight	approx. 550 kg
Cassette weight	3 - 5 kg
Electrical data	400 V~, AC- 50/60 Hz
Maximum power consumption	6,3 kW
Lengths of cable / connection plug	- / 3-phase grounded
Pressing force	-
Capacity	2-6 with MAP, 5- 9 without MAP
Start-up heating time	10 min
Trays/Film/Sealing	
Maximum sealable tray dimension	360 x 270 x 100 mm (>½ GN)
Maximum film width	446 mm
Sealing temperature	max 200°C
Sealing technique	Automatic
MAP - Modified Atmosphere Packaging	Yes
Vacuum chambers	1
Figure cutting	Yes
Accessories	
Spike Roll DF46	167331
High Oxygen Vacuum Pump 40 m³/h	166473
Food Filter DF46	168632
Tray Rails (for two cavities)	164723

FILMS THAT PROMOTE YOUR BUSINESS

If you want to make your food look delicious, encourage impulse purchases and ensure a leak-free, secure fit, Duniform® films tick the boxes. You can choose between Biobased, PP, PET and Universal films. These are crystal-clear and can be specified to prevent fogging. Even better, we can personalise them for your business – making your packaging a powerful promotional tool.



“In today’s globalised world, there is a growing demand for individualisation. Customising films offers a simple, cost-effective way to meet this need – and build your brand. Our customisation team can organise this for you.”

SEALING FILM FOR MENU FIBRE TRAYS



No	Article	Cooking temp. max °C	Sealing temp.	DF 10	DF 20	DF 15/25	DF 22	DF 32	DF 36	DF 44	DF 46	Thickness (µm)	Size (mm x m)	Qty/ Cart.
1	196585	220 (60min)	110-140°C	•	•	•	•	-	-	-	-	30	185x400	1
2	196586	220 (60min)	110-140°C	-	-	•	-	•	-	-	-	30	272x400	1

SEALING FILM FOR PP TRAYS



No.	Article	Cooking temp. max °C	Sealing temp.	DF 10	DF 20	DF 15/25	DF 22	DF 32	DF 36	DF 44	DF 46	Thickness µm	Size mm x m	Roll Ø mm	Qty/ Cart.
1	147974	100 (30min)	150 - 180°C	•	•	•	•	-	-	-	-	60	154x250	174	1
2	147975	100 (30min)	150 - 180°C	•	•	•	•	-	-	-	-	60	172x250	174	1
3	147910	100 (30min)	150 - 180°C	•	•	•	•	-	-	-	-	60	185x250	174	1
4	108078	100 (30min)	150 - 180°C	-	-	•*	•	•	-	-	-	60	230x500	227	1
5	107074	100 (30min)	150 - 180°C	-	-	•*	-	•	-	-	-	60	272x500	227	1
6	107075	100 (30min)	150 - 180°C	-	-	-	-	•	•	•	•	60	340x500	227	1
7	107073	100 (30min)	150 - 180°C	-	-	-	-	•	•	•	•	60	380x500	227	1
8	191010	100 (30min)	150 - 180°C	-	-	-	-	•	•	•	•	60	390x500	227	1
9	151548	100 (30min)	150 - 180°C	-	-	-	-	-	-	•	•	60	415x500	227	1
10	182539	100 (30min)	150 - 180°C	-	-	-	-	-	-	•	•	60	430x250	227	1

* Only with spike roll

SEALING FILM FOR PET TRAYS



No.	Article	Cooking temp. max °C	Sealing temp.	DF 10	DF 20	DF 15/25	DF 22	DF 32	DF 36	DF 44	DF 46	Thickness µm	Size mm x m	Roll Ø mm	Qty/ Cart.
1	162792	210 (30min)	160 - 250°C	•	•	•	•	-	-	-	-	40	115x400	175	1
2	162800	210 (30min)	160 - 250°C	•	•	•	•	-	-	-	-	40	185x400	175	1
3	162801	210 (30min)	160 - 250°C	-	-	•	•	•	-	-	-	40	240x400	175	1
4	162802	210 (30min)	160 - 250°C	-	-	•	-	•	-	-	-	40	272x400	175	1
5	162804	210 (30min)	160 - 250°C	-	-	-	-	•	•	•	•	40	340x400	175	1
6	162805	210 (30min)	160 - 250°C	-	-	-	-	•	•	•	•	40	380x400	175	1
7	162806	210 (30min)	160 - 250°C	-	-	-	-	•	•	•	•	40	390x400	175	1
8	162807	210 (30min)	160 - 250°C	-	-	-	-	-	-	•	•	40	410x400	175	1
9	198390	210 (30min)	160 - 250°C	-	-	-	-	-	-	•	•	40	415x400	175	1
10	162808	210 (30min)	160 - 250°C	-	-	-	-	-	-	•	•	40	446x400	175	1

UNIVERSAL SEALING FILM FOR PP/PET TRAYS



No.	Article	Cooking temp. max °C	Sealing temp.	DF 10	DF 20	DF 15/25	DF 22	DF 32	DF 36	DF 44	DF 46	Thickness µm	Size mm x m	Roll Ø mm	Qty/ Cart.
1	159847	180 (30min)	140 - 210°C	•	•	•	•	-	-	-	-	42	154x400	177	1
2	174553	180 (30min)	140 - 210°C	•	•	•	•	-	-	-	-	42	172x400	177	1
3	159848	180 (30min)	140 - 210°C	•	•	•	•	-	-	-	-	42	185x400	177	1
4	159849	180 (30min)	140 - 210°C	-	-	•	•	•	-	-	-	42	230x400	177	1
5	159850	180 (30min)	140 - 210°C	-	-	•	-	•	-	-	-	42	272x400	177	1
6	159851	180 (30min)	140 - 210°C	-	-	-	-	•	•	•	•	42	340x400	177	1
7	159843	180 (30min)	140 - 210°C	-	-	-	-	•	•	•	•	42	380x400	177	1
8	159844	180 (30min)	140 - 210°C	-	-	-	-	•	•	•	•	42	390x400	177	1
9	159845	180 (30min)	140 - 210°C	-	-	-	-	-	-	•	•	42	415x400	177	1
10	159846	180 (30min)	140 - 210°C	-	-	-	-	-	-	•	•	42	445x400	177	1

DUNIFORM®



FOOD'S BEST FRIEND

Call us food's best friend if you like. Because everything we do, we do for food. Everything we do, we do to deliver better food experiences. Welcome to better food experiences by Duniform!